



Electric Forklift Trucks
3500 and 4000 lb. Capacity
E18, E20, and E20 C/P
SERIES 346

Linde Material Handling

Linde

Safety

A key element of forklift safety is visibility of the load through the mast. Linde engineers have optimized the view with a unique mast design. In the main lift stages, chains have been replaced by cylinders allowing for a drastically wider field of vision. In addition, "ramp hold", "operator in-seat" demand, and an extensive range of standard features all contribute to the safe operation of this truck.

Unmatched Performance

Linde engineers have created a new motive power concept. The new drive axle includes the lift motor and all electrical power modules along with the standard twin drive motors, reduction gears, and maintenance free brakes. Combined with intelligent electronic controls, this system allows high performance without the energy drain of long power cables. Productivity will also get a boost from the quick acceleration this truck has to offer.

Ergonomic Excellence

Power and durability mean very little if driver fatigue becomes a problem. That's why we designed the 346 to the latest ergonomic principles. A multitude of features such as the armrest, full suspension seat, ample foot room, and adjustable steering column are all part of a comprehensive effort to keep the operator comfortable and secure.

Designed-in Durability

Durability is a Linde design objective. All components and assemblies are tested to meet rigorous longevity standards. Reliable electronic systems are the key to dependability and durability. Not only do these systems meet the required high standards, all systems are protected by a thermal protection package — adapting performance before permanent damage can occur. Robust electronics paired with a structurally sound chassis make the 346 a highly durable truck series.

Low Maintenance

All machines require maintenance, but the 346 series requires it only every 1000 hours. Design features like automatic deceleration, dual independent control systems, maintenance free brake system, and continuous on-board diagnostics keep this truck in perfect working condition. The AC system for all motors, operates without brushes and is completely sealed — extending component life and further reducing maintenance intervals.

Standard and optional equipment

Standard equipment:

36 or 48 volt chassis

Dual pedal travel control

Cushion tires

Lift out, low level, side battery discharge

Tilt cylinder 6 degrees forward/5 degrees back

Overhead guard 80.5"

Full adjustment comfort seat with tiltable armrest

Three individual hydraulic levers

Three function hydraulic valve

Two spot lights

Key switch

SB 350 battery connector

Options:

Single pedal travel control

Super-elastic (SE) tires

Side battery removal with slides

Side battery removal with rollers

Simple masts

Triple masts

Quad masts

Bottler's tilt

Integrated sideshifter

High comfort seat with tilt up armrest

Low profile OHG

Drive-in rack OHG

4 individual hydraulic control levers

4 function hydraulic valve

Hydraulic reeving

Additional lights

Warning devices

Cold storage protection

"EE" rating

Technical Data

E18

August 2010

Characteristics	1.1	Manufacturer		Linde	
	1.2	Model designation		E18	
	1.2.1	Chassis configuration		3-Wheel	
	1.3	Power unit: battery, diesel, LP gas		36-Volt Battery	48-Volt Battery
	1.4	Operation: manual, pedestrian, rider standing, rider seated, order picker		Rider seated	
	1.5	Load capacity	<i>Q lb</i>	3500	
	1.6	Load center	<i>c in</i>	24	24
	1.8	Load distance (front overhang)	<i>x in</i>	15.4	15.4
	1.9	Wheelbase	<i>y in</i>	55.9	55.9
Weight	2.1	Service weight with min. battery	<i>lb</i>	8355	8355
	2.2	Axle loading with load, front/rear	<i>lb</i>	10495 / 1361	10495 / 1361
	2.3	Axle loading without load, front/rear	<i>lb</i>	4411 / 3945	4411 / 3945
Wheels & Tires	3.1	Tire type - front/rear: cushion, cushion super elastic, pneumatic)		Cushion ¹⁾	Cushion ¹⁾
	3.2	Tire size: front	<i>in</i>	18 x 7 x 12.13	18 x 7 x 12.13
	3.3	Tire size: rear	<i>in</i>	15 x 5 x 11.25	15 x 5 x 11.25
	3.5	Wheels: number front/rear (x = driven)		2x / 2	2x / 2
	3.6	Track width, front	<i>b10 in</i>	35.0	35.0
	3.7	Track width, rear	<i>b11 in</i>	6.8	6.8
	Dimensions	4.1	Mast/fork carriage tilt: forward/back	<i>degrees</i>	6° / 5°
4.2		Height of mast lowered	<i>h1 in</i>	See mast table	See mast table
4.3		Free lift	<i>h2 in</i>	See mast table	See mast table
4.4		Lift	<i>h3 in</i>	See mast table	See mast table
4.5		Height of mast extended	<i>h4 in</i>	See mast table	See mast table
4.7		Height of overhead guard/cab	<i>h6 in</i>	80.5 ²⁾	80.5 ²⁾
4.8		Height of seat	<i>h7 in</i>	38.9	38.9
4.12		Height of tow coupling	<i>h10 in</i>	23.0	23.0
4.19		Overall length with 42" forks	<i>l1 in</i>	121.3	121.3
4.20		Length to fork face	<i>l2 in</i>	79.4	79.4
4.21		Overall width	<i>b1/b2 in</i>	42.0 ⁴⁾	42.0 ⁴⁾
4.22		Fork dimensions	<i>s/e/l in</i>	1.5 x 4.0 x 42.0	1.5 x 4.0 x 42.0
4.23		Fork carriage: class		Class II	Class II
4.24		Width of fork carriage	<i>b3 in</i>	38.6	38.6
4.31		Ground clearance under mast, with load	<i>m1 in</i>	2.9	2.9
4.32		Ground clearance, center of wheelbase	<i>m2 in</i>	3.3	3.3
4.33	Aisle width (must add load length and clearance)	<i>Ast in</i>	80 ³⁾	80 ³⁾	
4.35	Turning radius	<i>Wa in</i>	63.9	63.9	
Performance	5.1	Travel speed, with/without load	<i>mph</i>	8.7 / 8.7	10 / 10
	5.2	Lifting speed, with/without load	<i>fpm</i>	59 / 89	60 / 102
	5.3	Lowering speed, with/without load	<i>fpm</i>	96 / 78	96 / 78
	5.6	Maximum tractive force, with/without load (5 min. rating)	<i>lbs</i>	2450 / 2450	2200 / 2200
	5.7	Climbing ability, with/without load	<i>%</i>	16 / 23	16 / 23
	5.10	Service brake		Wet disc	Wet disc
Drive	6.1	Drive motor (60 min. rating)	<i>hp</i>	2x 5.4	2x 6.1
	6.2	Lift motor (15% rating)	<i>hp</i>	10.0	13.4
	6.3	Battery voltage	<i>V</i>	36	48
	6.4	Battery compartment dimension (l x w x h; maximum)	<i>in</i>	25.0 x 38.9 x 25.9 ⁵⁾	25.0 x 38.9 x 25.9 ⁵⁾
	6.5	Battery weight (US battery, minimum / maximum)	<i>lb</i>	2155 / 2730	2155 / 2730
Other	8.2	Working pressure for attachments	<i>psi</i>	2465	2465
	8.3	Oil flow for attachments	<i>gpm</i>	8.5	8.5

1) SE tire available

2) Lower OHG available

3) Add length of load plus operating clearance

4) 46" wide with 200/50-10 SE tires

5) Optional battery removal system will reduce compartment height: 23.34 w/battery rollers — 25.40 w/battery slides

Technical Data

E20

August 2010

Characteristics	1.1	Manufacturer		Linde
	1.2	Model designation		E20
	1.2.1	Chassis configuration		3-Wheel
	1.3	Power unit: battery, diesel, LP gas		36-Volt Battery 48-Volt Battery
	1.4	Operation: manual, pedestrian, rider standing, rider seated, order picker		Rider seated
	1.5	Load capacity	<i>Q lb</i>	4000
	1.6	Load center	<i>c in</i>	24 24
	1.8	Load distance (front overhang)	<i>x in</i>	15.4 15.4
	1.9	Wheelbase	<i>y in</i>	55.9 55.9
Weight	2.1	Service weight with min. battery	<i>lb</i>	8796 8796
	2.2	Axle loading with load, front/rear	<i>lb</i>	11366 / 1430 11366 / 1430
	2.3	Axle loading without load, front/rear	<i>lb</i>	4412 / 4384 4412 / 4384
Wheels & Tires	3.1	Tire type - front/rear: cushion, cushion super elastic, pneumatic)		Cushion ¹⁾ Cushion ¹⁾
	3.2	Tire size: front	<i>in</i>	18 x 7 x 12.13 18 x 7 x 12.13
	3.3	Tire size: rear	<i>in</i>	15 x 5 x 11.25 [`] 15 x 5 x 11.25
	3.5	Wheels: number front/rear (x = driven)		2x / 2 2x / 2
	3.6	Track width, front	<i>b10 in</i>	35.0 35.0
	3.7	Track width, rear	<i>b11 in</i>	6.8 6.8
	Dimensions	4.1	Mast/fork carriage tilt: forward/back	<i>degrees</i>
4.2		Height of mast lowered	<i>h1 in</i>	See mast table See mast table
4.3		Free lift	<i>h2 in</i>	See mast table See mast table
4.4		Lift	<i>h3 in</i>	See mast table See mast table
4.5		Height of mast extended	<i>h4 in</i>	See mast table See mast table
4.7		Height of overhead guard/cab	<i>h6 in</i>	80.5 ²⁾ 80.5 ²⁾
4.8		Height of seat	<i>h7 in</i>	38.9 38.9
4.12		Height of tow coupling	<i>h10 in</i>	23.0 23.0
4.19		Overall length with 42" forks	<i>l1 in</i>	121.3 121.3
4.20		Length to fork face	<i>l2 in</i>	79.4 79.4
4.21		Overall width	<i>b1/b2 in</i>	42.0 ⁴⁾ 42.0 ⁴⁾
4.22		Fork dimensions	<i>s/e/l in</i>	1.5 x 4.0 x 42.0 1.5 x 4.0 x 42.0
4.23		Fork carriage: class		Class II Class II
4.24		Width of fork carriage	<i>b3 in</i>	38.6 38.6
Performance		5.1	Travel speed, with/without load	<i>mph</i>
	5.2	Lifting speed, with/without load	<i>fpm</i>	59 / 89 60 / 102
	5.3	Lowering speed, with/without load	<i>fpm</i>	96 / 78 96 / 78
	5.6	Maximum tractive force, with/without load (5 min. rating)	<i>lbs</i>	2450 / 2450 2200 / 2200
	5.7	Climbing ability, with/without load	<i>%</i>	14 / 22 14 / 22
	5.10	Service brake		Wet disc Wet disc
	Drive	6.1	Drive motor (60 min. rating)	<i>hp</i>
6.2		Lift motor (15% rating)	<i>hp</i>	10.0 13.4
6.3		Battery voltage	<i>V</i>	36 48
6.4		Battery compartment dimension (l x w x h; maximum)	<i>in</i>	25.0 x 38.9 x 25.9 ⁵⁾ 25.0 x 38.9 x 25.9 ⁵⁾
6.5		Battery weight (US battery, minimum / maximum)	<i>lb</i>	2155 / 2730 2155 / 2730
Other	8.2	Working pressure for attachments	<i>psi</i>	2465 2465
	8.3	Oil flow for attachments	<i>gpm</i>	8.5 8.5

1) SE tire available

2) Lower OHG available

3) Add length of load plus operating clearance

4) 46" wide with 200/50-10 SE tires

5) Optional battery removal system will reduce compartment height: 23.34 w/battery rollers — 25.40 w/battery slides

Technical Data

E20C/P

August 2010

Characteristics	1.1	Manufacturer		Linde	
	1.2	Model designation		E20 C/P	
	1.2.1	Chassis configuration		4-Wheel	
	1.3	Power unit: battery, diesel, LP gas		36-Volt Battery	48-Volt Battery
	1.4	Operation: manual, pedestrian, rider standing, rider seated, order picker		Rider seated	
	1.5	Load capacity	<i>Q lb</i>	4000	
	1.6	Load center	<i>c in</i>	24	24
	1.8	Load distance (front overhang)	<i>x in</i>	15.4	15.4
	1.9	Wheelbase	<i>y in</i>	61.0	61.0
Weight	2.1	Service weight with min. battery	<i>lb</i>	8827	8827
	2.2	Axle loading with load, front/rear	<i>lb</i>	11433 / 1393	11433 / 1393
	2.3	Axle loading without load, front/rear	<i>lb</i>	4729 / 4097	4729 / 4097
Wheels & Tires	3.1	Tire type - front/rear: cushion, cushion super elastic, pneumatic)		Cushion ¹⁾	Cushion ¹⁾
	3.2	Tire size: front	<i>in</i>	18 x 7 x 12.13	18 x 7 x 12.13
	3.3	Tire size: rear	<i>in</i>	16 x 6 x 10.5'	16 x 6 x 10.5'
	3.5	Wheels: number front/rear (x = driven)		2x / 2	2x / 2
	3.6	Track width, front	<i>b10 in</i>	35.0	35.0
	3.7	Track width, rear	<i>b11 in</i>	31.0	31.0
	Dimensions	4.1	Mast/fork carriage tilt: forward/back	<i>degrees</i>	6° / 5°
4.2		Height of mast lowered	<i>h1 in</i>	See mast table	See mast table
4.3		Free lift	<i>h2 in</i>	See mast table	See mast table
4.4		Lift	<i>h3 in</i>	See mast table	See mast table
4.5		Height of mast extended	<i>h4 in</i>	See mast table	See mast table
4.7		Height of overhead guard/cab	<i>h6 in</i>	80.5 ²⁾	80.5 ²⁾
4.8		Height of seat	<i>h7 in</i>	38.9	38.9
4.12		Height of tow coupling	<i>h10 in</i>	23.0	23.0
4.19		Overall length with 42" forks	<i>l1 in</i>	127.9	127.9
4.20		Length to fork face	<i>l2 in</i>	85.9	85.9
4.21		Overall width	<i>b1/b2 in</i>	42.0 ⁴⁾	42.0 ⁴⁾
4.22		Fork dimensions	<i>s/e/l in</i>	1.5 x 4.0 x 42.0	1.5 x 4.0 x 42.0
4.23		Fork carriage: class		Class II	Class II
4.24		Width of fork carriage	<i>b3 in</i>	38.6	38.6
4.31		Ground clearance under mast, with load	<i>m1 in</i>	2.9	2.9
4.32		Ground clearance, center of wheelbase	<i>m2 in</i>	3.3	3.3
4.33		Aisle width (must add load length and clearance)	<i>Ast in</i>	86 ³⁾	86 ³⁾
4.35	Turning radius	<i>Wa in</i>	70.4	70.4	
Performance	5.1	Travel speed, with/without load	<i>mph</i>	8.7 / 8.7	10 / 10
	5.2	Lifting speed, with/without load	<i>fpm</i>	59 / 89	60 / 102
	5.3	Lowering speed, with/without load	<i>fpm</i>	96 / 78	96 / 78
	5.6	Maximum tractive force, with/without load (5 min. rating)	<i>lbs</i>	2450 / 2450	2200 / 2200
	5.7	Climbing ability, with/without load	<i>%</i>	14 / 22	14 / 22
	5.10	Service brake		Wet disc	Wet disc
Drive	6.1	Drive motor (60 min. rating)	<i>hp</i>	2x 5.4	2x 6.1
	6.2	Lift motor (15% rating)	<i>hp</i>	10.0	13.4
	6.3	Battery voltage	<i>V</i>	36	48
	6.4	Battery compartment dimension (l x w x h; maximum)	<i>in</i>	25.0 x 38.9 x 25.9 ⁵⁾	25.0 x 38.9 x 25.9 ⁵⁾
	6.5	Battery weight (US battery, minimum / maximum)	<i>lb</i>	2155 / 2730	2155 / 2730
Other	8.2	Working pressure for attachments	<i>psi</i>	2465	2465
	8.3	Oil flow for attachments	<i>gpm</i>	8.5	8.5

1) SE tire available

2) Lower OHG available

3) Add length of load plus operating clearance

4) 46" wide with 200/50-10 SE tires

5) Optional battery removal system will reduce compartment height: 23.34 w/battery rollers — 25.40 w/battery slides

Downrating Charts*

E18 346 Series E20 346 Series E20 C/P 346 Series

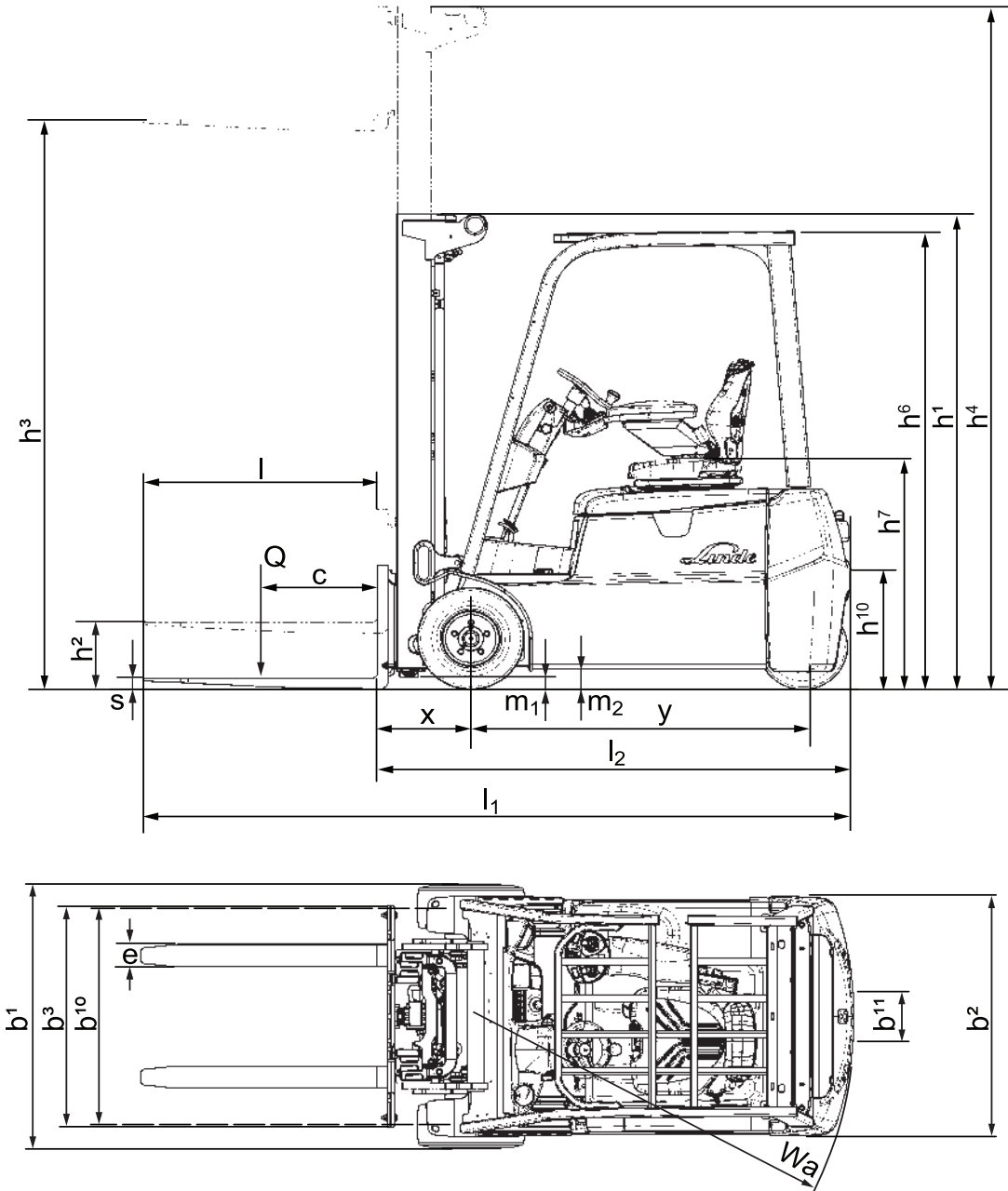
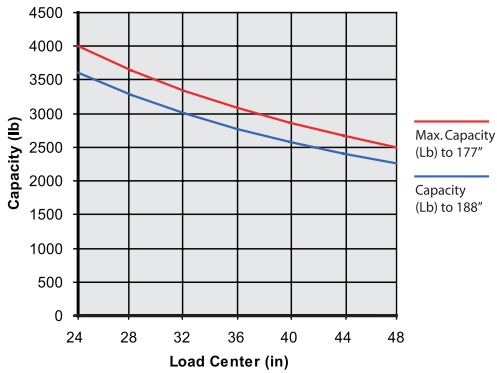
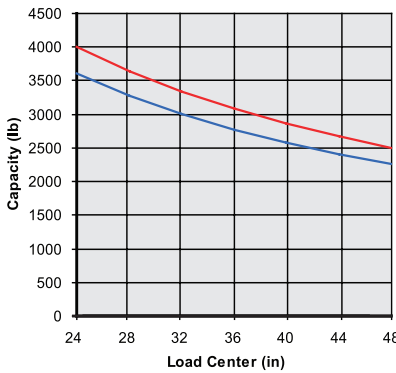
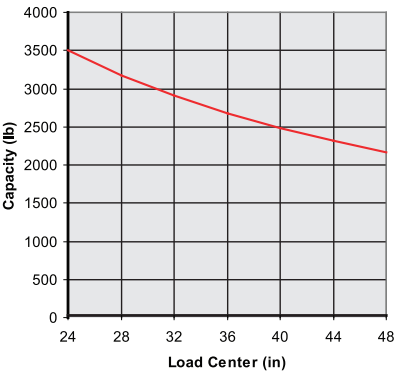

Capacity*

E18

1.5" x 4" x 42" Std. Taper Class II Forks**
 Cushion Tires 18 x 7 x 12.125 Drive Tires**
 Class II Sideshifter • Back Tilt Angle = 5°

Mast Capacity Table

h1	h3	h2	
80.0	122.0	00.0	Simplex
84.0	129.5	00.0	Simplex
91.5	145.5	00.0	Simplex
77.5	168.0	53.0	Triplex
79.5	174.0	55.0	Triplex
84.0	188.0	59.5	Triplex

Capacity (lb) @ 24" Load Center**

Std. Carriage	Integral SS Carriage	Hang-on SS Carriage*
3500	3500	3250
3500	3500	3250
3500	3500	3250
3500	3500	3250
3500	3500	3250
3500	3500	3250

E20

1.5" x 4" x 42" Std. Taper Class II Forks**
 Cushion Tires 18 x 7 x 12.125 Drive Tires**
 Class II Sideshifter • Back Tilt Angle = 5°

Mast Capacity Table

h1	h3	h2	
80.0	122.0	00.0	Simplex
84.0	129.5	00.0	Simplex
91.5	145.5	00.0	Simplex
77.5	168.0	53.0	Triplex
79.5	174.0	55.0	Triplex
84.0	188.0	59.5	Triplex

Capacity (lb) @ 24" Load Center**

Std. Carriage	Integral SS Carriage	Hang-on SS Carriage*
4000	4000	3750
4000	4000	3750
4000	4000	3750
4000	4000	3750
4000	4000	3750
3600	3600	3350

E20 C/P

1.5" x 4" x 42" Std. Taper Class II Forks**
 Cushion Tires 18 x 7 x 12.13 Drive Tires**
 Class II Sideshifter • Back Tilt Angle = 5°

Mast Capacity Table

h1	h3	h2	
80.0	122.0	00.0	Simplex
84.0	129.5	00.0	Simplex
91.5	145.5	00.0	Simplex
77.5	168.0	53.0	Triplex
79.5	174.0	55.0	Triplex
84.0	188.0	59.5	Triplex

Capacity (lb) @ 24" Load Center**

Std. Carriage	Integral SS Carriage	Hang-on SS Carriage*
4000	4000	3750
4000	4000	3750
4000	4000	3750
4000	4000	3750
4000	4000	3750
3600	3600	3350

* For quick reference only, contact factory for detailed ratings. **Capacity ratings can be affected by changing forks, load center, and/or drive tires.

Features

Electrical system

- 36 or 48 volts
- AC technology
- Enclosed motors
- Maintenance free and sealed systems



Linde twin drive pedals

- Quick directional changes
- Short pedal stroke
- No leg fatigue
- Increased productivity
- Precise maneuvering

Energy efficiency

- Excellent heat management
- Energy return system
- Fully programmable performance
- Optimized energy utilization
- Dual AC drive motors
- Limited use of power cables

→ Low maintenance

- Maintenance free multi-disc brakes
- 1000 hour intervals
- Continuous on-board diagnostics

Linde operator compartment

- Ergonomically optimized armrest
- Generous amounts of foot room
- Fully adjustable suspension seat
- Ergonomically designed steering wheel

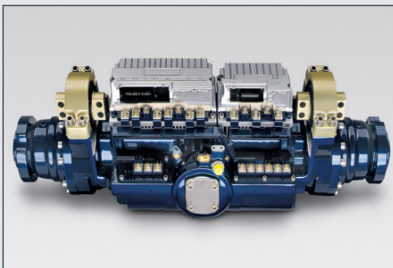

Linde load control

- Safe, precise load handling
- Short hydraulic levers
- Control levers built into the armrest
- On demand power

Productivity

- High uptime
- Fast acceleration
- Quick battery change
- Large battery compartment

Safety

- Quick-set parking brake
- Low-lift side battery removal
- Emergency power disconnect
- "Operator in seat" requirement



Linde Combi-axle (E20 C/P)

- Excellent stability on uneven surfaces
- Aisle width and turning radius similar 3-wheel version
- Exceptional maneuverability in confined areas
- Combined advantage of center pivot and articulating axle



For more information on Linde material handling equipment, please contact:

KION North America Corporation
2450 West 5th North Street, Summerville, SC 29483
Phone: (843) 875-8000 Truck Sales Fax: (843) 875-8471
E-mail: trucksales.na@kiongroup.com
www.kion-na.com